

3M™ MetPak™ 2-FB Inverse Socket

2 mm 5-Row, Vertical, Solder or Press-Fit Tail

MP2 Series

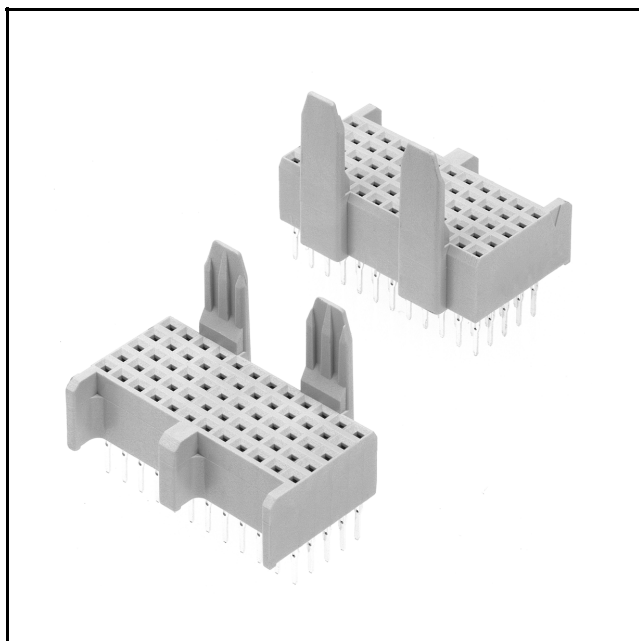

- Guiding alignment feature eliminates bent pins on backplane
- Footprint compatible with standard Futurebus+®
- Ideal for hot swapping
- End-to-end stackable
- Vertical socket on backplane
- Offset dual-beam contact minimizes insertion force
- Mates with MP2-P and MP2-PS Series
- Rear plug-up tails for midplane applications
- See Regulatory Information Appendix (RIA) for chemical compliance information

Date Modified: March 27, 2007

TS-1121-04
Sheet 1 of 4

Physical

Insulation

Material: High Temp LCP
Flammability: UL 94V-0
Color: Beige

Contact

Material: Copper Alloy

Plating

Underplating: 50 μ" [1.27 μm] Nickel
Wiping Area: See Ordering Information
Solder Tails: See Ordering Information

Electrical

Current Rating: Signal: 1.5 A - All contacts simultaneously
Insulation Resistance: 10³ MΩ
Withstanding Voltage: 1000 V_{AC}

Environmental

Temperature Rating: -55°C to +125°C

UL File No.: E68080

* Futurebus+ is a registered trademark of the Institute of Electrical and Electronic Engineers, Inc. (IEEE)
MetPak is a trademark of 3M Company.

3M™ MetPak™ 2-FB Inverse Socket

2 mm 5-Row, Vertical, Solder or Press-Fit Tail

MP2 Series

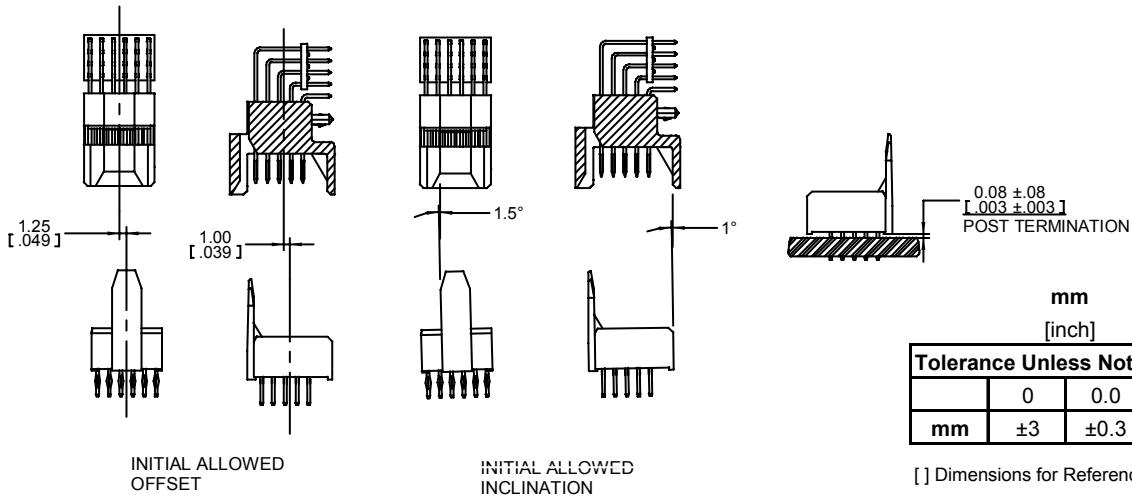
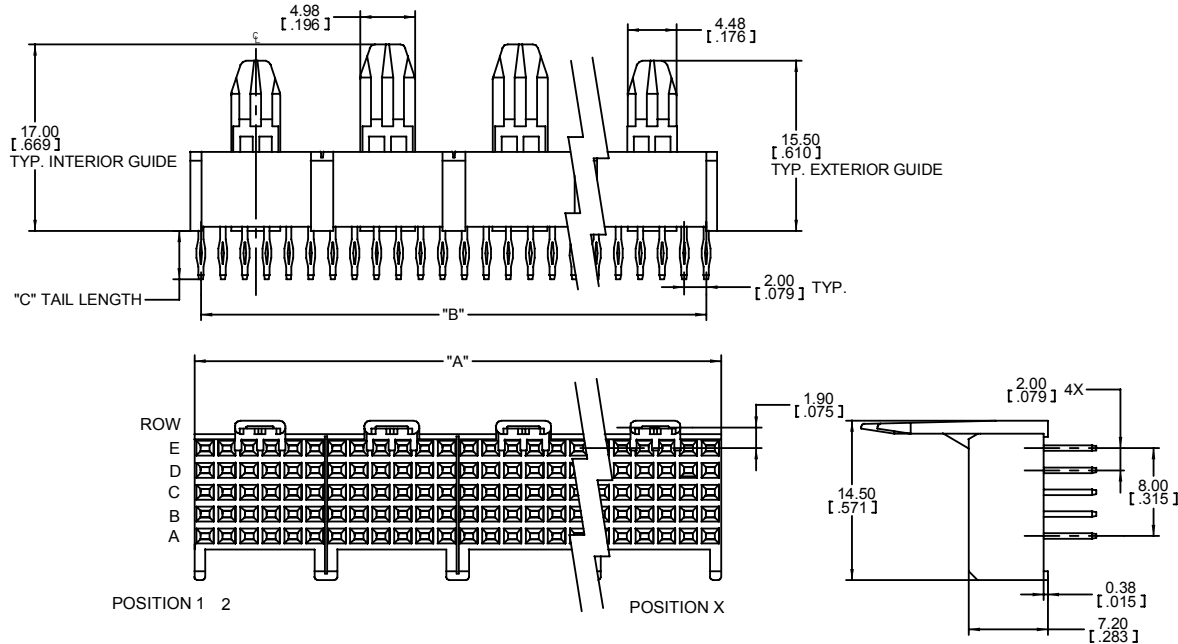

Tolerance Unless Noted		
	mm	[inch]
	0	0.0
mm	±3	±0.3
	±0.00	±0.13

[] Dimensions for Reference Only

Notes:

1. For special contact loading pattern, contact 3M.
2. Refer to IEC 61076-4-104 Futurebus+® global standard.
3. "Press Fit" describes a contact tail having a compliant section designed to make a reliable electrical connection with a plated through-hole (PTH) in a printed circuit board, typically a "back plane."



Ordering Information

MP2 - RXXX - 5XXX - XXXXX

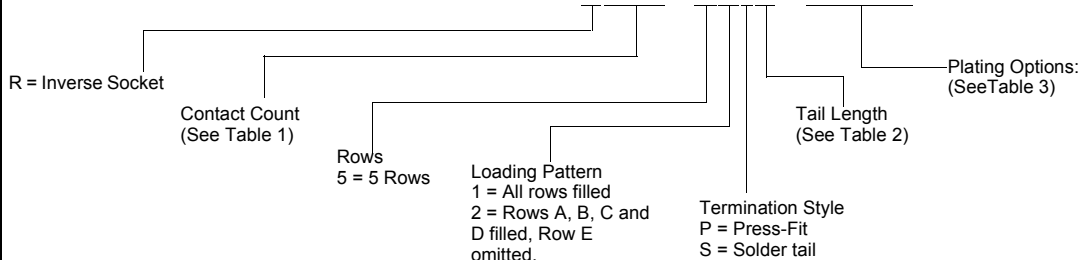

TS-1121-04
Sheet 2 of 4

3M™ MetPak™ 2-FB Inverse Socket

2 mm 5-Row, Vertical, Solder or Press-Fit Tail

MP2 Series

Table 1 - Connector & Row Lengths						
Pin Count	Dim. "A" mm		Dim "B" mm		Rows	Block Count
	[inch]		[inch]			
030	11.95	[0.471]	10.00	[0.394]	5	1
060	23.95	[0.943]	22.00	[0.866]	5	2
090	35.95	[1.415]	34.00	[1.339]	5	3
120	47.95	[1.889]	46.00	[1.811]	5	4
150	59.95	[2.36]	58.00	[2.283]	5	5
180	71.95	[2.833]	70.00	[2.756]	5	6
210	83.95	[3.305]	82.00	[3.228]	5	7
240	95.95	[3.778]	94.00	[3.701]	5	8
270	107.95	[4.251]	106.00	[4.173]	5	9
300	119.95	[4.722]	118.00	[4.646]	5	10

Table 2 - Tail Length		
Contact-to-PC Board Tail Termination Option No.		Dim. "C"
Solder	Press-Fit*	
1	1	4.35 [0.171]

*Compliant-Pin Tail

Table 3 - Plating & Regulatory			
Plating Suffix	Press-Fit Tails*	Solder Tails	Plating Composition
TG	RIA E2 & C2 apply	RIA E3 & C2 apply	0.25 µm [10 µm] Min. Au Contact Area 2.54 µm [100 µm] Min. SnPb Tail Area 1.27 µm [50 µm] Min. Ni all over
TG30	RIA E2 & C2 apply	RIA E3 & C2 apply	0.76 µm [30 µm] Min. Au Contact Area 2.54 µm [100 µm] Min. SnPb Tail Area 1.27 µm [50 µm] Min. Ni all over
TR30	RIA E2 & C2 apply	RIA E3 & C2 apply	0.08 µm [3 µm] Min. Au Contact Area 0.67 µm [27 µm] Min. PdNi Contact Area 2.54 µm [100 µm] Min. SnPb Tail Area 1.27 µm [50 µm] Min. Ni all over
TR40B	RIA E2 & C2 apply	RIA E3 & C2 apply	0.13 µm [5 µm] Min. Hard Au Contact Area, Lubricated 1.02 µm [40 µm] Min. PdNi Contact Area 0.10 µm [4 µm] Min. Pd Contact Area 2.54 µm [100 µm] Min. SnPb Tail Area 1.27 µm [50 µm] Min. Ni all over
FJ	RIA E1 & C1 apply	RIA E1 & C1 apply	0.25 µm [10 µm] Min. Au Contact Area 5.08 µm [200 µm] Min. Matt Whisker Mitigating Sn Tail Area 1.27 µm [50 µm] Min. Ni all over
KR	RIA E1 & C1 apply	RIA E1 & C1 apply	0.76 µm [30 µm] Min. Au Contact Area 5.08 µm [200 µm] Min. Matt Whisker Mitigating Sn Tail Area 1.27 µm [50 µm] Min. Ni all over
RF	RIA E1 & C1 apply	RIA E1 & C1 apply	1.27 µm [50 µm] Min. Au Contact Area, Lubricated 5.08 µm [200 µm] Min. Matt Whisker Mitigating Sn Tail Area 1.27 µm [50 µm] Min. Ni all over
LR	RIA E1 & C1 apply	RIA E1 & C1 apply	0.08 µm [3 µm] Min. Au Contact Area 0.67 µm [27 µm] Min. PdNi Contact Area 5.08 µm [200 µm] Min. Matt Whisker Mitigating Sn Tail Area 1.27 µm [50 µm] Min. Ni all over
PD	RIA E1 & C1 apply	RIA E1 & C1 apply	0.13 µm [5 µm] Min. Hard Au Contact Area, Lubricated 1.02 µm [40 µm] Min. PdNi Contact Area 0.10 µm [4 µm] Min. Pd Contact Area 5.08 µm [200 µm] Min. Matt Whisker Mitigating Sn Tail Area 1.27 µm [50 µm] Min. Ni all over

*Compliant-Pin Tail

TS-1121-04
Sheet 3 of 4

3M™ MetPak™ 2-FB Inverse Socket

2 mm 5-Row, Vertical, Solder or Press-Fit Tail

MP2 Series

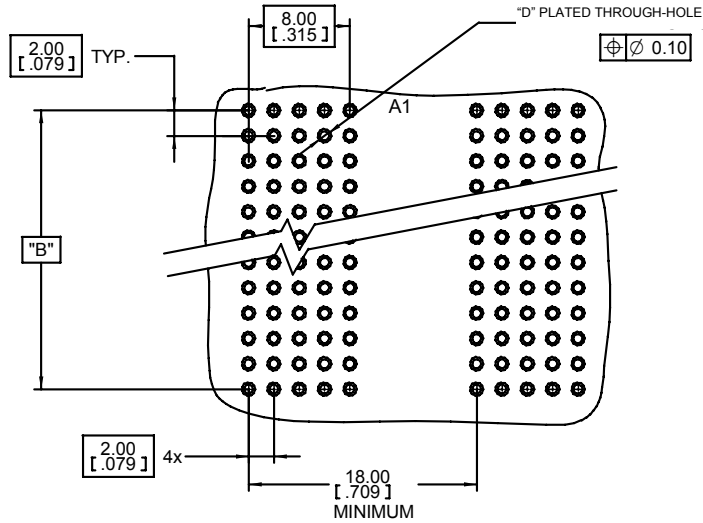

RECOMMENDED PRESS-FIT AND SOLDER TAIL PCB HOLE MOUNTING PATTERN

Tolerance Unless Noted		
	mm	[Inch]
	0.0	0.00
- mm	± .3	± .25

[] Dimensions for Reference only

Table 4 -- HOLE PLATING For TG, TG30, TR30, TR40B FINISHES ONLY

HOLE	Finished Dia. mm [in]	Cu Thickness mm [in]	SnPb Thickness microns [μ"]	Drilled Hole Dia. mm [in]
"D"	0.65-0.80 [.0256-.0315]	0.025 [.001] min	15 [600] max	0.81-0.86 [.0319-.0339]

Table 5 -- HOLE PLATING For FJ, KR, RF, LR, and PD FINISHES ONLY

Hole	Finished Dia. mm [in]	Cu Thickness mm [in]	Immersion Matte Sn Thickness microns [μ"]	Electrolytic Au Thickness microns [μ"]	OSP ENTEK Thickness microns [μ"]	Drilled Hole Dia. mm [in]
"D"	0.700-0.800 [.0276-.0315]	0.025-0.045 [0.001-0.002]	0.5 - 2.5 [20 - 100]	0.1 - 0.5 [4 - 20]	0.2 - 0.5 [8 - 20]	0.830-0.860 [.0330-.0340] or 0.85mm [#66] TWIST DRILL

TS-1121-04
Sheet 4 of 4

Regulatory Information Appendix

3M Electronic Solutions Division/Interconnect

EUROPE

Appendix E1: European Union RoHS

Directive 2002/95/EC, Restriction of the Use of Certain Hazardous Substances in Electrical & Electronic Equipment, as amended by EU Commission Decision 2005/618/EC.

This product is RoHS Compliant 2005/95/EC.

“RoHS Compliant 2005/95/EC” means that the product or part (“Product”) does not contain any of the substances in excess of the maximum concentration values in EU Directive 2002/95/EC, as amended by Commission Decision 2005/618/EC, unless the substance is in an application that is exempt under EU RoHS. Unless otherwise stated by 3M in writing, this information represents 3M’s best knowledge and belief based upon information provided by third party suppliers to 3M.

In the event any product is proven not to conform with 3M’s Regulatory Information Appendix, then 3M’s entire liability and Buyer’s exclusive remedy will be in accordance with the Warranty stated below.

Appendix E2: European Union RoHS

Directive 2002/95/EC, Restriction of the Use of Certain Hazardous Substances in Electrical & Electronic Equipment, as amended by EU Commission Decision 2005/618/EC.

This product contains lead in the compliant pin area in excess of the maximum concentration value allowed but is compliant by exemption under EU Commission Decision 2005/747/EC.

“RoHS Compliant 2005/95/EC” means that the product or part (“Product”) does not contain any of the substances in excess of the maximum concentration values in EU Directive 2002/95/EC, as amended by Commission Decision 2005/618/EC, unless the substance is in an application that is exempt under EU RoHS. Unless otherwise stated by 3M in writing, this information represents 3M’s best knowledge and belief based upon information provided by third party suppliers to 3M.

In the event any product is proven not to conform with 3M’s Regulatory Information Appendix, then 3M’s entire liability and Buyer’s exclusive remedy will be in accordance with the Warranty stated below.

Appendix E3: European Union RoHS

Directive 2002/95/EC, Restriction of the Use of Certain Hazardous Substances in Electrical & Electronic Equipment as amended by Commission Decision 2005/618/EC.

This product contains lead in the solder tail area in excess of the maximum concentration value allowed.

Unless otherwise stated by 3M in writing, this information represents 3M’s best knowledge and belief based upon information provided by third party suppliers to 3M.

In the event any product is proven not to conform with 3M’s Regulatory Information Appendix, then 3M’s entire liability and Buyer’s exclusive remedy will be in accordance with the Warranty stated below.

Appendix E4: European Union RoHS

Directive 2002/95/EC, Restriction of the Use of Certain Hazardous Substances in Electrical & Electronic Equipment, as amended by EU Commission Decision 2005/618/EC.

This product contains decaBDE in the insulating material in excess of the maximum concentration value allowed but is compliant by exemption under EU Commission Decision 2005/17/EC.

“RoHS Compliant 2005/95/EC” means that the product or part (“Product”) does not contain any of the substances in excess of the maximum concentration values in EU Directive 2002/95/EC, as amended by Commission Decision 2005/618/EC, unless the substance is in an application that is exempt under EU RoHS. Unless otherwise stated by 3M in writing, this information represents 3M’s best knowledge and belief based upon information provided by third party suppliers to 3M.

In the event any product is proven not to conform with 3M’s Regulatory Information Appendix, then 3M’s entire liability and Buyer’s exclusive remedy will be in accordance with the Warranty stated below.



Appendix C1: China RoHS

Electronic Industry Standard of the People's Republic of China, SJ/T11363-2006, Requirements for Concentration Limits for Certain Hazardous Substances in Electronic Information Products.

This symbol, per Marking for the Control of Pollution Caused by Electronic Information Products, SJ/T11364-2006, means that the product or part **does not** contain any of the following substances in excess of the following maximum concentration values in any homogeneous material: (a) 0.1% (by weight) for lead, mercury, hexavalent chromium, polybrominated biphenyls or polybrominated diphenyl ethers; or (b) 0.01% (by weight) for cadmium. Unless otherwise stated by 3M in writing, this information represents 3M's best knowledge and belief based upon information provided by third party suppliers to 3M.

In the event any product is proven not to conform with 3M's Regulatory Information Appendix, then 3M's entire liability and Buyer's exclusive remedy will be in accordance with the Warranty stated below.



Appendix C2: China RoHS

Electronic Industry Standard of the People's Republic of China, SJ/T11363-2006, Requirements for Concentration Limits for Certain Hazardous Substances in Electronic Information Products.

This symbol, per Marking for the Control of Pollution Caused by Electronic Information Products, SJ/T11364-2006, means that the product or part **does** contain a substance, as detailed in the chart below, in excess of the following maximum concentration values in any homogeneous material: (a) 0.1% (by weight) for lead, mercury, hexavalent chromium, polybrominated biphenyls or polybrominated diphenyl ethers; or (b) 0.01% (by weight) for cadmium. Unless otherwise stated by 3M in writing, this information represents 3M's best knowledge and belief based upon information provided by third party suppliers to 3M.

The numerical reference in the symbol above should not be construed as a representation regarding the product's life or an extension of a product warranty. The product warranty is stated below. In the event any product is proven not to conform with 3M's Regulatory Information Appendix, then 3M's entire liability and Buyer's exclusive remedy will be in accordance with the product Warranty stated below.

产品中有毒有害物质或元素的名称及含量 Name and Content of Hazardous Substances or Elements

部件名称 (Part or Component Name)	有毒有害物质或元素 (Hazardous Substances or Elements)					
	铅 (Pb)	汞 (Hg)	镉 (Cd)	六价铬 (Cr(VI))	多溴联苯 (PBB)	多溴二苯醚 (PBDE)
端子镀层 (contact plating)	×	○	○	○	○	○
○: 表示该有毒有害物质在该部件所有均质材料中的含量均在SJ/T11363-2006 标准规定的限量要求以下。(Indicates that this hazardous substance contained in all of the homogeneous materials for this part is below the limit requirement in SJ/T11363-2006.) ×: 表示该有毒有害物质至少在该部件的某一均质材料中的含量超出SJ/T11363-2006 标准规定的限量要求。(Indicates that this hazardous substance contained in at least one of the homogeneous materials used for this part is above the limit requirement in SJ/T11363-2006.)						

Important Notice

All statements, technical information, and recommendations related to 3M's products are based on information believed to be reliable, but the accuracy or completeness is not guaranteed. Before using this product, you must evaluate it and determine if it is suitable for your intended application. You assume all risks and liability associated with such use. Any statements related to the product which are not contained in 3M's current publications, or any contrary statements contained on your purchase order shall have no force or effect unless expressly agreed upon, in writing, by an authorized officer of 3M.

Warranty; Limited Remedy; Limited Liability.

This product will be free from defects in material and manufacture for a period of ninety (90) days from the time of purchase. **3M MAKES NO OTHER WARRANTIES INCLUDING, BUT NOT LIMITED TO, ANY IMPLIED WARRANTY OF MERCHANTABILITY OR FITNESS FOR A PARTICULAR PURPOSE.** If this product is defective within the warranty period stated above, your exclusive remedy shall be, at 3M's option, to replace or repair the 3M product or refund the purchase price of the 3M product. **Except where prohibited by law, 3M will not be liable for any indirect, special, incidental or consequential loss or damage arising from this 3M product, regardless of the legal theory asserted.**



Electronic Solutions Division

6801 River Place Blvd.
Austin, TX 78726-9000
800/225-5373
www.3M.com/interconnects